

Reach calculations based upon the following:

ORIGINAL COPY

1. Truck bed height = 48"
2. Center of post to rear edge of conveyor = 56"

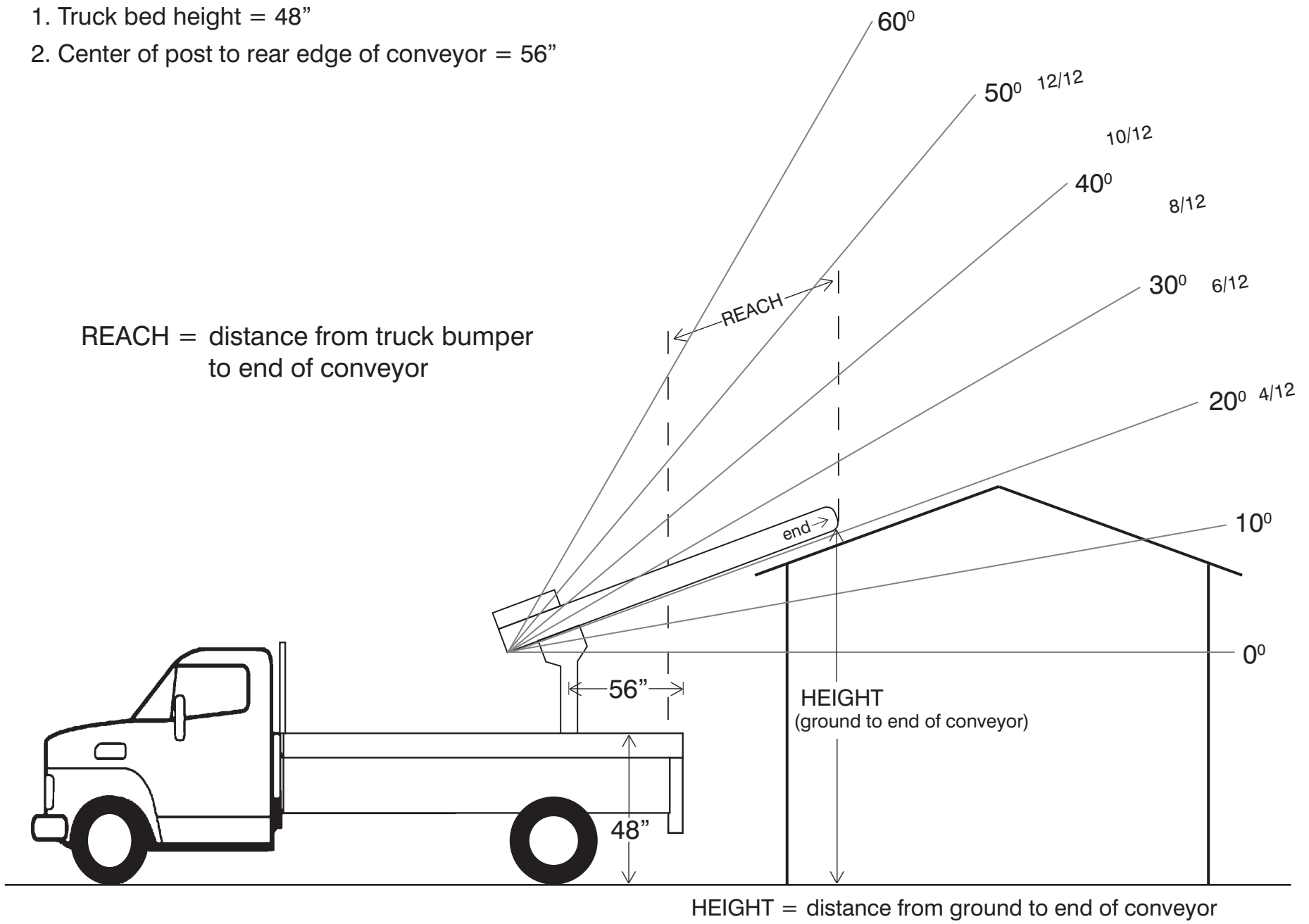

HEIGHT (H)

ORIGINAL COPY

REACH (R)	CONV. LENGTH	0° R / H	10° R / H	20° R / H	30° R / H	40° R / H	50° R / H	60° R / H
	24'		19.5/7.5	19/11	18.5/14	17/17	15/20	12.5/22.5
26'		21.5/7.5	21/11.5	20/15	18.5/18	16.5/21	13.5/24	10.5/26
28'		23.5/7.5	23/12	22/15.5	20.5/19	18/19	15/22.5	11.5/28
30'		25.5/7.5	25/12	24/16	22/20.5	19.5/24	16.5/27	12.5/29.5
31'		26.5/7.5	26/12.5	25/16.5	23/20.5	20.5/24.5	17/28	13/30.5
32'		27.5/7.5	27/12.5	26/17	24/21	21/25	17.5/20.5	14/31.5
34'		29.5/7.5	29/13	27.5/17.5	25.5/22	22.5/26.5	18.5/30	14.5/33
36'		31.5/7.5	31/13.5	29.5/18.5	27.5/23	24/27.5	20/31.5	15/35
37'		32.5/7.5	32/13.5	30.5/18.5	28/23.5	25/28.5	20.5/32.5	16/35.5
38'		33.5/7.5	33/14	31.5/19	29/24	25.5/29	21.5/33	16.5/36.5
40'		35.5/7.5	35/14.5	33.5/20	31/25.5	27.5/30.5	22.5/35	17.5/38.5
43'		38.5/7.5	38/15	36/20.5	33.5/27	29.5/32.5	24.5/37	19/41